

# Pump **AQUA-MINI**

LOW RUNNING COST, LOW NOISE LEVEL

Designed for above-ground pool. Optional built-in timer.



low dB



low  
energy



easy

1. Pump body with pre-filter and rotating transparent lid for easy installation and maintenance
2. Supplied with union connectors and flexible hose adaptors
3. Asynchronous, Two poles
4. Class insulation: 130(B)
5. IPX5 Waterproof standard
6. Built-in thermal protection
7. External heat sink
8. Available in 50Hz or 60Hz for 220V/110V
9. Specially designed unions are compatible for both imperial and metric standards

 **Emaux**  
water technology

**Pool & Spa Equipment**



SAA

# Aqua-Mini Pump

## Technical Information:

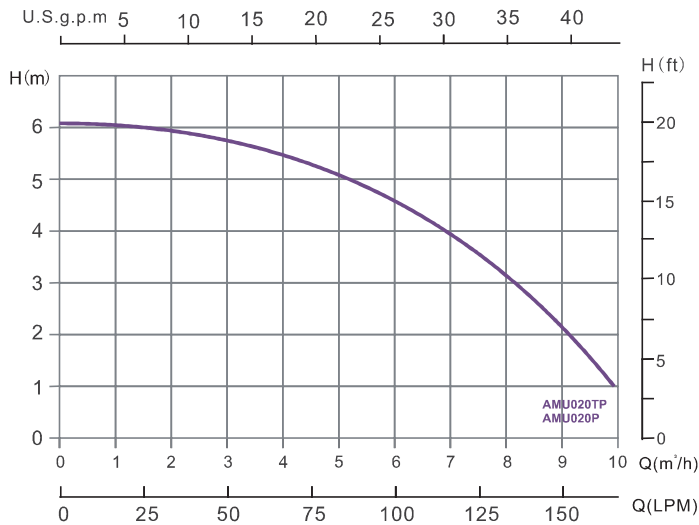

Note: The performance curve above is for 50Hz models



Timer option



## Product Information and Dimensions:

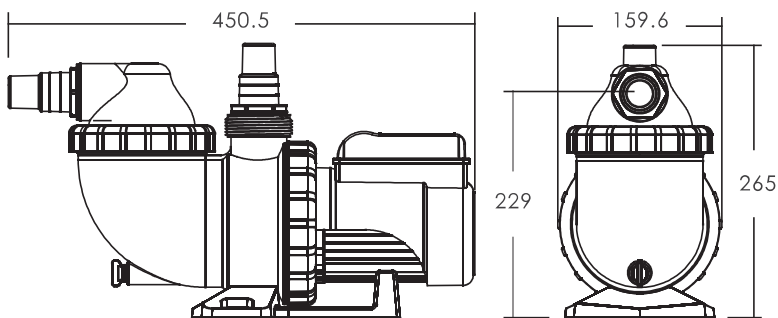

Aqua-Mini Pump is designed for above ground pools

Model 50Hz	Input (kW)	Current (AMP)	Noise (dB)	Head (m)			
				2	3	4	5
AMU020TP	0.25	1.2	55	9.1	8.1	6.9	5.1
AMU020P	0.25	1.2	55	9.1	8.1	6.9	5.1

Code 220V/50Hz	Code 110V/60Hz	Code 220V/60Hz	Model	Description	Horsepower	Connection Size	Adaptor	Weight (kg)
88028401	88028501	88028301	AMU020TP	0.20HP Aqua-Mini Pump (with timer & pre-filter)	0.2hp	1.5 inch 50mm	1 1/4" & 1 1/2" 32 & 38mm	4.2
88027801	88027901	88027701	AMU020P	0.20HP Aqua-Mini Pump (with pre-filter)	0.2hp	1.5 inch 50mm	1 1/4" & 1 1/2" 32 & 38mm	4.2

## EMAUX WATER TECHNOLOGY CO., LTD

ADDRESS: 2/F, Lockhart Centre, No. 301-307  
Lockhart Road, Wanchai, Hong Kong  
PHONE +852 2832 9880  
www.emauxgroup.com

Pool & Spa Equipment

## Available from: