

Super-Power Pump

STRONG, RELIABLE AND OUTSTANDING

For residential pool & spa



 **Emaux**
water technology

CE RoHS COMPLIANT 2002/95/EC SAA

Pool & Spa Equipment

SIGNATURE COLLECTION

Product Features

- 1) Asynchronous, two poles motor
- 2) Class insulation 155(F)
- 3) Thermal or over current protection
- 4) Pump casing ABS + glass fiber, Impeller PPO, Strainer basket and base in PP + glass fiber
- 5) Motor shaft - SS316, Seals bellows - EPDM, stationary face - SIC, rotating face - Graphite, Spring - SS316
- 6) Self-Priming up to 3.3m above water level
- 7) Testing pressure 50 PSI (3.5 Bar)
- 8) Basket Volume 2 litres

**Ring lock seal design eliminate suction leaks
and maximize suction efficiency**

Engineered and built for pool professionals



Technical Information

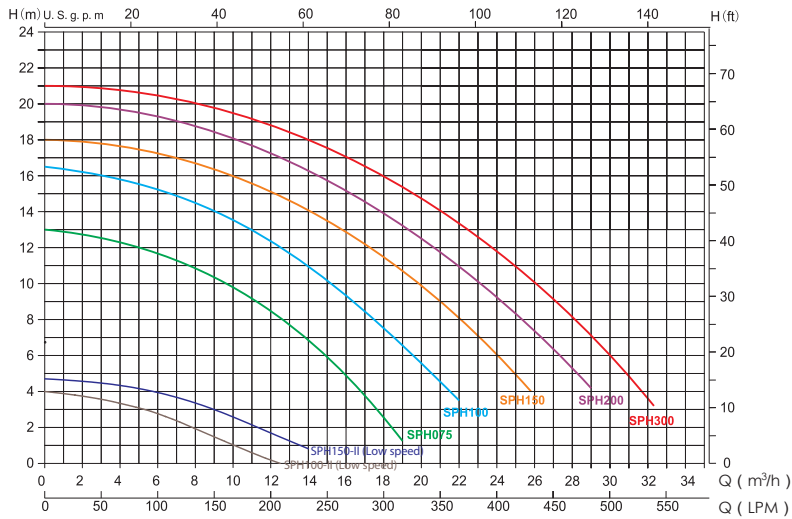

Model 50Hz	Input (kW)	Current (AMP)	Noise (dB)	Head (m)					
				6	8	10	12	14	16
SPH075	0.75	3.5	65	15	12.5	9.5	5	--	--
SPH100	1.10	5	65	19.5	17.5	15.2	12.5	9	3
SPH150	1.50	6.8	67	24	22	19.9	17.5	14	10
SPH200	1.80	8.2	67	27.5	25.5	23	21.7	18	14.5
SPH300	2.20	10	68	30	28.5	26	23.8	21	18
SPH100-II	1.10	5	65	19.5	17.5	15.2	12.5	9	3
SPH150-II	1.50	6.8	65	24	22	19.9	17.5	14	10

Code 220V/50Hz	Code 220V/60Hz	Model	Connection Size	Horsepower	Weight(kg)	Capacitance 220V	A (mm)
88029604	88029704	SPH075	1.5"(50mm)ID / 2"(63mm)OD	0.75hp	13.6	20µF	652
88029605	88029705	SPH100	1.5"(50mm)ID / 2"(63mm)OD	1.0hp	13.8	25 µF	652
88029607	88029707	SPH150	1.5"(50mm)ID / 2"(63mm)OD	1.5hp	14.0	25 µF	652
88029608	88029708	SPH200	1.5"(50mm)ID / 2"(63mm)OD	2.0hp	14.2	30 µF	652
88029609	88029709	SPH300	1.5"(50mm)ID / 2"(63mm)OD	3.0hp	14.5	35 µF	682
9023212	/	SPH100-II	1.5"(50mm)ID / 2"(63mm)OD	1.0hp	14.7	/	682
9023213	/	SPH150-II	1.5"(50mm)ID / 2"(63mm)OD	1.5hp	15.0	/	682

Product Dimension

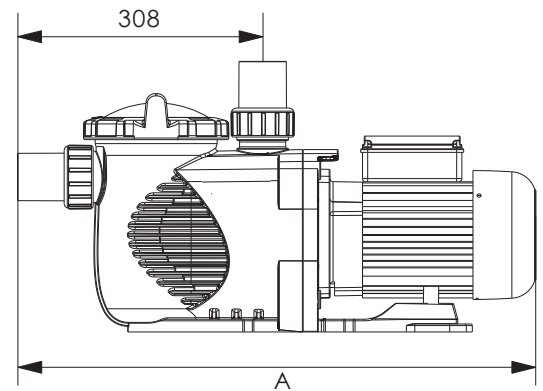
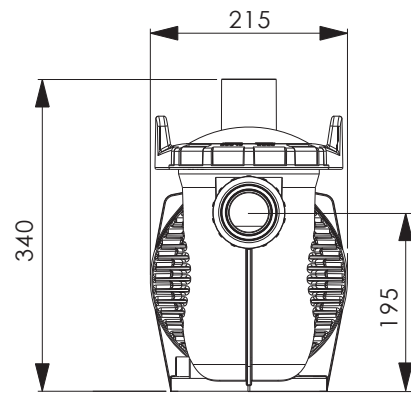

EMAUX WATER TECHNOLOGY CO., LTD

ADDRESS G/F 41 TIN HAU TEMPLE ROAD,
NORTH POINT, HONG KONG

PHONE +852 2832 9880

www.emauxgroup.com

 **STRIVE FOR CLEAR WATER**

Available from:

ALL SPECIFICATIONS ARE SUBJECT TO CHANGE WITHOUT NOTICE.
© 2018 EMAUX WATER TECHNOLOGY CO., LTD. ALL RIGHTS RESERVED.

www.emauxgroup.com