



HAYWARD[®]

SUPER II[®] ECO

>>> SINGLE SPEED PUMP

HIGH-PERFORMANCE PUMP SERIES

PERFORMANCE OF A LIFETIME

Power your system with the energy efficient Super II ECO pump series from Hayward. These super efficient pumps are built to last and engineered to perform even under the most demanding conditions.

Convenient features include a see-through cover so pool owners know exactly when to empty the extra large debris basket and a housing design that makes it as quiet as it is dependable.



Super II ECO®

Single Speed Pump

PERFORMANCE
OF A LIFETIME.

- **Heavy-duty, high-performance motor** with advanced airflow ventilation for quieter, cooler operation
- **Full flow hydraulics** allow a greater flow at a lower operational cost
- **Simple access** with the motor and entire drive group assembly removable without disturbing pipe or mounting connections
- **Large prefilter basket** with tool-less removal for longer operation between cleanings
- **Self-priming** with suction lift up to 1.8m above water level



Performance Curves

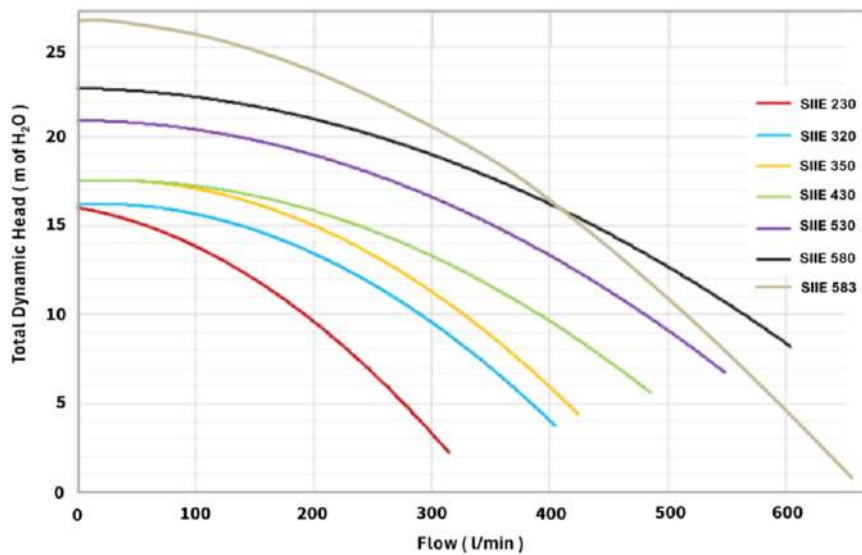

Technical Specification

Max. water temp.	40°C
Motor Specification	220-240V 50Hz 2 Pole Class F
Ingress Protection	IP55
Connections (mm)	40/50
Rated Noise DB(A)@1M	<70
Housing/impeller/lid	PP+GF/PPO(Noryl®)/PC

Ordering Information

MODEL	INPUT POWER (KW)	INPUT AMPS	RATED HP	L x W (mm)	WEIGHT (KG)
SIIE320	0.74	3.30	0.75	569 x 240	12.50
SIIE320	0.98	4.34	1.00	569 x 240	13.40
SIIE350	1.10	5.10	1.25	594 x 240	15.30
SIIE430	1.38	6.23	1.50	594 x 240	15.30
SIIE530	1.86	8.33	2.00	618 x 240	19.05
SIIE580	2.33	10.46	3.00	618 x 240	20.80
**SIIE583	2.70	8.2/4.7	3.00	630 x 240	22.00

**SIIE 583 380-415V 3ph Typical installation for in-ground pools use 8m-10m head

Dimensions

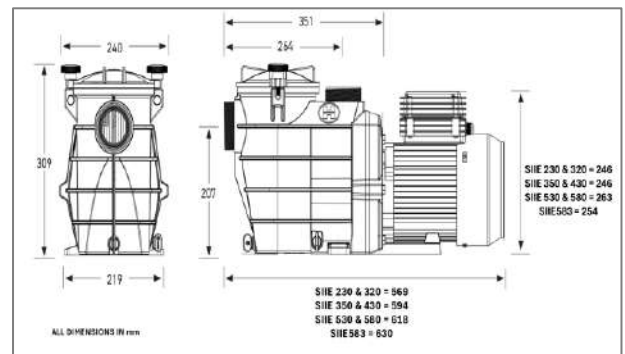

>> haywardimg.com >> img@hayward.com



We Build Better.™

International Marketing Group
8175 W. Buckeye Rd. ► Phoenix AZ 85043 USA